

# #01

POLYRACKTECH-GROUP

# 19" FRONT PANELS

// Product information

---



# 19" FRONT PANELS

// Product information

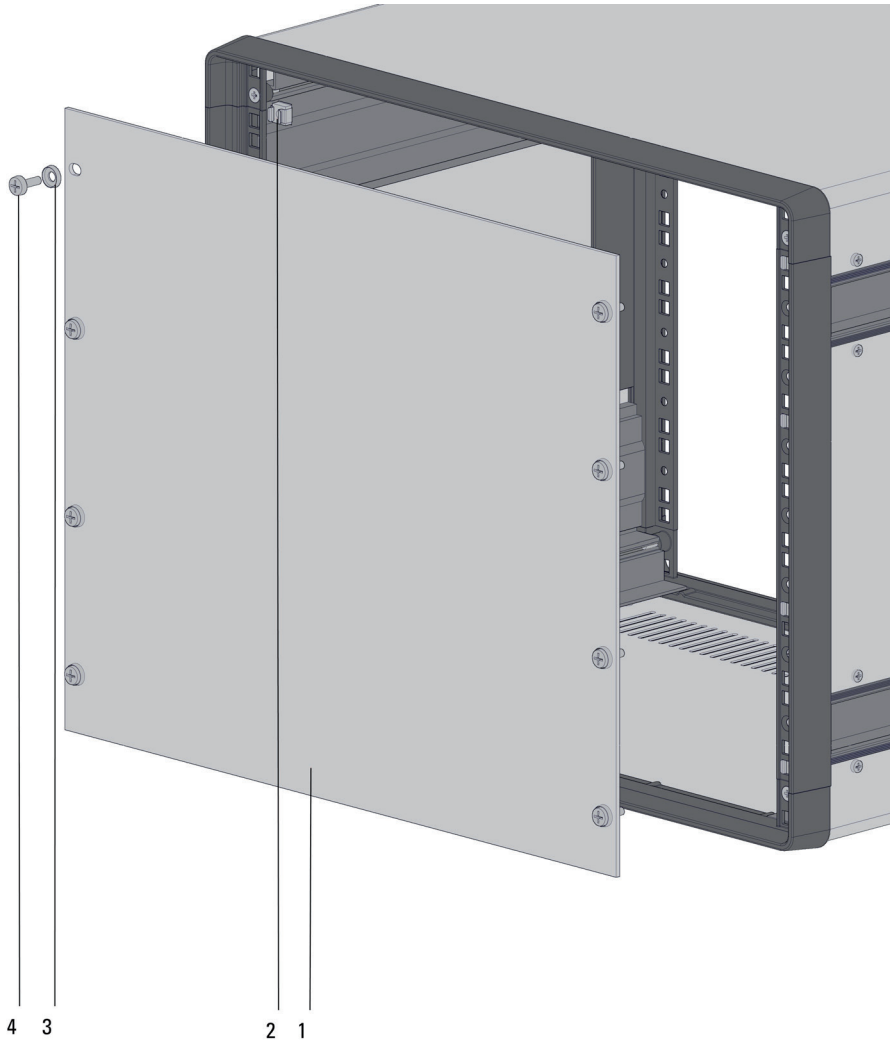

## Product information

19" front panels are designed for use in 19" cases and cabinets. They are standardly used as front panels. They can be custom-manufactured with cutouts and surface finishing in accordance with customer requirements.

## Configuration example

The diagram shows the typical configuration of a 19" front panel mounted in a case

- 1 Front panel
- 2 Cage nut\*
- 3 Plastic washer\*
- 4 Cylinder head screw\*

Parts marked with \* are not included in the scope of delivery of the basic unit, i.e. must be ordered separately.

## // Notes on standards, units of measurement and mounting / overall dimensions

### Inner and outer dimensions

- IEC 60297-3-101
- IEC 60297-3-102
- IEC 60297-3-103
- IEEE 1101.11

### Unit of height U

Measurement unit for height in 19" rack systems

1 U = 44.45 mm

### Increment unit HP

Measurement unit for width in 19" rack systems

1 HP = 5.08 mm

### Dimensions specified in ordering tables

The dimensions, in particular those given in U and HP, are specified in relation to the application:

Height  $H = (n \text{ (U)} \times 44.45 \text{ mm}) - 4.8 \text{ mm}$

Usable width  $W = (n \text{ (HP)} \times 5.08 \text{ mm}) - 0.3 \text{ mm}$

The depth  $D$  (in mm) indicates the total depth of the case without handles, connectors, etc.

# //02

19" FRONT PANELS

# 19" FRONT PANELS

// Basic units

## Basic units

19" front panels are intended for use in 19" cabinets or in cases designed to accept 19" dimensions

## Features of the basic units

19" Front panels

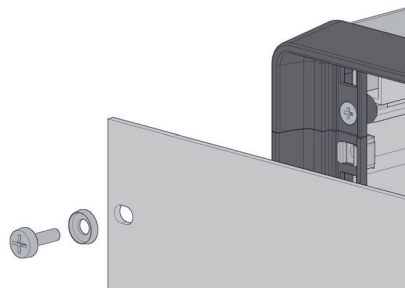

# //02

19" FRONT PANELS

# 19" FRONT PANELS

// Product information

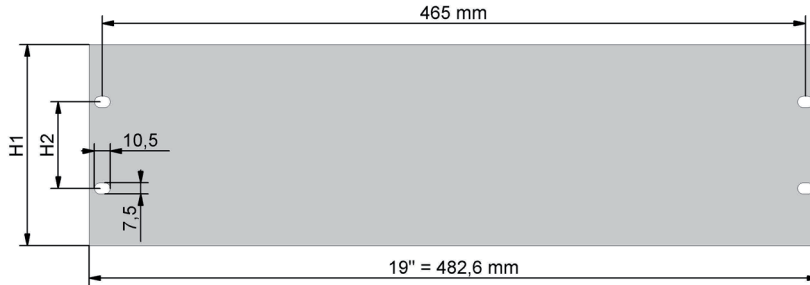

Dimension diagrams

Front view

See ordering table for dimensions H1, H2

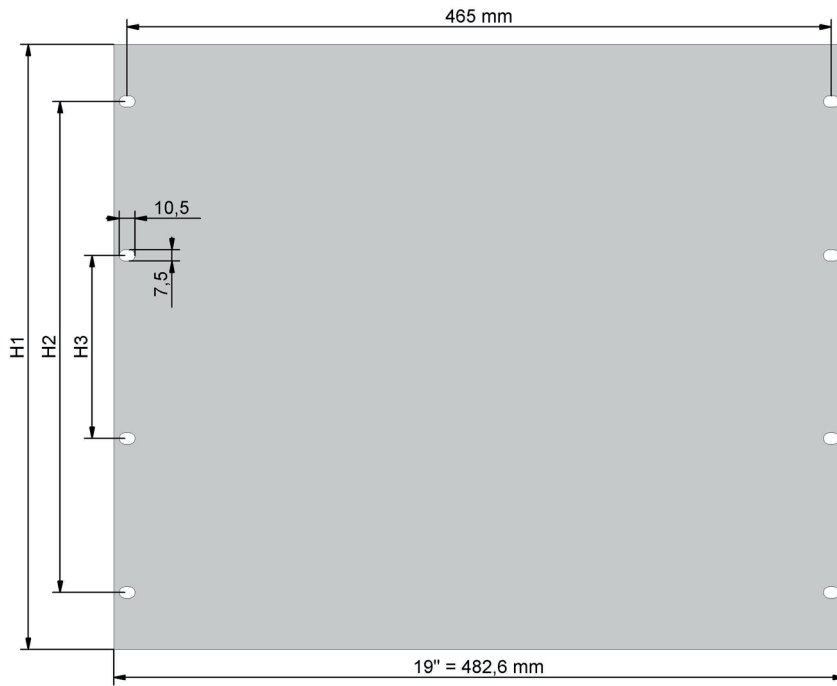

Front view

See ordering table for dimensions H1, H2, H3

Dimensions

U	H1	H2	H3
1 U	43,6	31,7	-
2 U	88,1	76,2	-
3 U	132,5	57,1	-
4 U	177,0	101,6	-
5 U	221,4	146,0	-
6 U	265,9	190,5	-
7 U	310,3	234,9	-
8 U	354,8	279,4	-
9 U	399,2	323,9	120,6
12 U	532,6	457,2	190,5
15 U	665,9	590,5	235,0